

Assembly Instructions

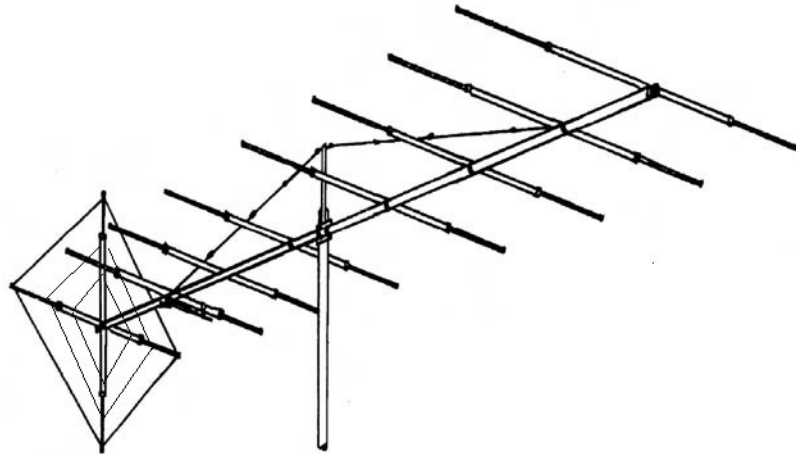

FLAT 8

8 ELEMENT 10/11 METER BEAM



Maco Antennas - a Division of Charles Electronics, LLC
302 S. East St.
Mt. Carroll, IL 61053

815-244-3500
www.macoantennas.net

MACO FLAT 8

PACKING LIST

<u>PART</u>	<u>QTY</u>	<u>Q.D.</u>	<u>SIZE</u>	<u>LENGTH</u>	<u>DESCRIPTION</u>	<u>CHECKLIST</u>
T39	2	3"	.060"	20"	ALUMINUM TUBING	_____
T36	1	2.875"	.125"	48"	ALUMINUM TUBING	_____
T11P	9	5/8"	.050"	72"	ALUM TUBING SLOTTED BOTH ENDS	_____
T01	14	1/2"	.050"	72"	ALUMINUM TUBING	_____
V02P	1		1 1/2" X 1 1/2"	36"	VERTICAL GUY SUPPORT/3 HOLES ONE END	_____
P04P	1		1/4" X 6"	18"	PLATE 3" BOOM TO 2" MAST PIPE	_____
WD3P	1		6/18	50"	STEEL GUY CABLE	_____
W05P	1		7/14	90"	BARE COPPER WIRE	_____
FA2P	4			48"	MULTI SCREEN FIBERGLASS RODS	_____
2600	1				5,000 WATT GAMMA MATCH	_____
Z08P	2			4"	GAMMA STRAPS	_____
S42	1				FEMALE COAX CONN W/MNTG NUTS	_____
<u>HARDWARE BAG #1</u>						
U03	14		3"		PLATED U-BOLTS	_____
U01	5		2"		PLATED U-BOLTS	_____
N03	38		5/16"		LOCK NUTS	_____
<u>HARDWARE BAG #2</u>						
S03	14		3"		PLATED SADDLES	_____
S01	5		2"		PLATED SADDLES	_____
<u>HARDWARE BAG #3</u>						
BE3P	9				3" BOOM TO ELEMENT MOUNTS	_____
<u>HARDWARE BAG #4</u>						
W58P	18		5/8"		EXTRUDED ALUMINUM CLAMPS	_____
EG2	6				EGG INSULATORS	_____
S28	1		1/2"	3 1/2"	HEX BOLT	_____
S21	25		10-24	1/2"	MACHINE SCREWS	_____
N11	25		10-24		SQUARE NUTS	_____
N15	1		1/2"		HEX NUTS	_____
N16	1		1/2"		LOCK WASHERS	_____
N17	3		1/2"		FLAT WASHERS	_____
N18	2		5/16"	4"	EYE BOLTS W/(2) N01 NUTS EACH	_____
PL2	14		.437"		PLASTIC CAPS - BLACK	_____
N12	4		#10		LOCK WASHERS	_____
N26	4		#10		FLAT WASHERS	_____
Z02P	2		1/2"	4"	GAMMA STRAPS	_____
PL6	1			3"	PLASTIC CAP - BLACK	_____
PL6R	1			3"	PLASTIC CAP - RED	_____
	3				FIBERGLASS ROD KIT W/4 SCREWS	_____
	1				INSTRUCTION SHEET-FLAT 8	_____
	1				INSTRUCTION SHEET-LASER 500	_____
	1				TIP SHEET	_____
	1				WARRANTY SHEET	_____

WHEN ORDERING PARTS, ALWAYS GIVE PART NUMBER AND DESCRIPTION.

Please note: In an effort to keep the price on Maco Antennas down, we have decided not to clean up all the burrs and rough edges on the parts. We recommend that you deburr and clean up each part with files, sandpaper, etc. so that they go together easily. We are aware this needs to be done but have elected not to do it to save you the money we would have to add to the price of the kit for this service.

MACO FLATSIDER 8

FLATSIDER 8 ADDITIONS to the LASER 500 INSTRUCTIONS

(These instructions MODIFY THE LASER 500 INSTRUCTIONS attached.)

1 - THE DIFFERENCE

The FLATSIDER 8 is the LASER 500 with three changes:

- (1) The vertical elements and associated hardware are removed.
- (2) A 5000 Watt Gamma Assembly is included.
- (3) The Reflector (screen) is redesigned with the addition of 2 more wires, which some claim increases the rejection.

2 - NEW INSTRUCTIONS

The changes DO NOT CHANGE THE ASSEMBLY INSTRUCTIONS EXCEPT AS FOLLOWS:

- (1) Pay no attention to assembly of the VERTICAL PARTS EXCEPT for the REFLECTOR METAL PARTS.
- (2) THIS PART of these instructions IS WHAT IS NEEDED TO ASSEMBLE THE FIBER GLASS and WIRE PART of the REFLECTOR
- (3) P.S.: This antenna could just as easily be installed vertically.

DISREGARD the FIRST PARAGRAPH of FIGURE 3C, REFLECTOR ASSEMBLY instructions.
USE THIS !!!!

The length of the wires on the reflector is super critical so we have revised the instructions to make it easier to get it right. Take the copper wire and unwind it on a flat surface being careful not to kink it. Fasten one end around a nail and stretch the whole piece 2 inches (this straightens It). Now mark off from the nail to which one end is connected ,19 ft. and drive another nail. This Is 1/2 of the total wire length of 38 ft. when finished. Now measure 38 ft. and 4 Inches and cut this piece off. Put the rest of the wire out of the way for now. Take the 38 ft. 4 in wire and run It around the two nails which are 19 ft. apart ,stretch tight ,and using the 4 in overlap , splice the two ends together as shown In FIGURE 3. NOW YOU HAVE THE WIRE for THE REFLECTOR and it is the CORRECT OVERALL LENGTH OF 38 FT. INSTALL THIS WIRE AS SHOWN IN FIGURE 3 AND written about In paragraphs 2-3 and 4 of the instructions FIGURE 3 REFLECTOR ASSEMBLY. Stretch Is as tight as It was around the nails.

When the outer wire is Installed then thread the Inner wires ,one at a time through the holes In the fiberglass rods, stretch snug, and splice.

THIS COMPLETES ASSEMBLY WHICH IS DIFFERENT THAN THE LASER 500.

Now enjoy the best MACO CB BEAM we know about.

MACO LASER 500

ASSEMBLY INSTRUCTIONS

Figure 1: General Instructions

This drawing depicts an overall view of what the antenna should look like upon completion of assembly. Refer to Figures 2 through 4 for specific assembly details. All hardware should be coated with a silicon rubber sealant or similar compound to ensure that wind vibration does not cause it to work loose.

Upon completion of assembly, install the red plastic cap (PL6R) on the director end of the antenna, and the black plastic cap (PL6) on the reflector end. This will allow you to determine at a glance the direction of transmit and receive.

Figure 2: Boom and Guy Assembly

Mark the center of the boom coupler (T36P) and slide both boom sections over each end so that they meet in the center. Next, mount the boom-to-mast plate (P04P) and the guy support (V02P) at the center of the boom using 3" U-bolts, saddles, and hardware as shown in detail 2A).

The first step in assembling the guy cable is to cut 8 pieces of the following lengths off the roll of cable.

- 2 pcs 2' 0" Long
- 2 pcs 2' 10" Long
- 2 pcs 6' 1-1/2" Long
- 2 pcs 6' 10" Long

Take both 2' 0" lengths and attach one end of each to an egg insulator (EG2) and the other end to an eyebolt (N18), so that the distance between the eyebolt and insulator is 1 foot. Make all your wraps and shown in details 2C & 2D. Attach both eyebolts to the vertical guy support with 5/16" hex nuts as shown in detail 2C. Run the outside hex nuts only a couple of turns onto ends of the eyebolts and leave the inside nuts loose so that you can take the slack out of the cable later.

Now take one 6' 1-1/2" length and attach it to the cable and insulator on the vertical guy support that goes toward the driven element end of the boom. Fasten the other 6' 1-1/2" length to the end of the cable assembly with an egg insulator. Next attach the 2' 10" length to the end with another egg insulator in the same manner.

You should have two 6' 10" lengths and one 2' 10" length remaining. Assemble and attach them to the vertical guy support on the other side in the same manner. (At this point it will be necessary to go on to element assembly and mounting before attaching the guy cables to the boom.)

After you have mounted your elements wrap the ends of both guy cable assemblies around the boom at the 5th director on one end and the driven element on the other end. Pull out as much slack as possible and make your wrap as shown in detail 2D.

Take the rest of the slack out of the cables by tightening the outside hex nuts on the eyebolts. Lock them in place by tightening the inside hex nuts.

This antenna is designed for mounting on a 2" OD heavy duty mast. Mount using 2" U-bolts, saddles, and hardware as shown in detail 2B.

<p style="text-align: center;">CAUTION: TAKE CARE TO AVOID ANY CONTACT WITH OVERHEAD POWER LINES WHEN RAISING YOUR ANTENNA. SERIOUS OR FATAL INJURY COULD RESULT.</p>
--

Maco Antennas - a Division of Charles Electronics, LLC

302 S. East St.
Mt. Carroll, IL 61053

815-244-3500
www.macoantennas.net

FIGURE 3 ELEMENT ASSEMBLY

Prior to assembling elements slide a boom-to-element mount (**BE3P**) onto each of the (16) element center sections (**TIIP**). Assemble each element as shown using the clamps and hardware specified. Refer to the element table to determine dimensions for each element. Install a black plastic cap (**PL2**) onto both ends of each element. Assemble the reflector elements in the same manner, sliding the fiberglass arms approximately 6 inches into the ends of the center sections (**TIIP**). Snug the clamps but don't tighten at this time because the arms will have to be adjusted after installing the reflector wire.

FIGURE 3B ELEMENT MOUNTING

Mark each element at the center and be sure that the boom-to-element mounts (**BE3P**) are centered on the elements before tightening hardware. Starting 1" from the director end of the boom, mount each element using 3" U-bolts, saddles, boom-to-element mounts and hardware as shown. Refer to Figures 1 & 3B for element spacing dimensions. (At this point go back and complete the guy cable assembly.)

FIGURE 3C REFLECTOR ASSEMBLY

The length of the reflector wire is very critical. It must be the correct length to operate correctly. Take the wire (**WO4P**) and uncoil it making sure that there are no kinks; secure it to a nail. Pull the wire until it stretches an inch or so. The easy way to get the correct length for the reflector loop is as follows:

1. Drive 2 nails in a board or fence 1/2 the length of the loop apart --which is 228" (5.790m) between them.
2. Stretch the wire around the nails by hand as tightly as possible and splice ends together. Solder the splice. Remove one nail and remove the loop. Cut any excess wire off.
3. Loosely assemble the machine screws (**S2 1**), flatwashers (**N26**), lockwashers (**N12**), and hex nuts (**N06**) onto the lugs of the fiberglass arms, adjusting the length as shown.
4. Tighten 3 of the 4 clamps that hold the fiberglass rods.
5. Install the wire as shown.
6. Tighten the wire by pulling the fourth fiberglass rod until the wire is the same tightness as it was around the nails. The wire loop is now the correct length. Note the total length of the loop is critical, and also is the length of each side. REMEMBER: Reflector dimensions are only preliminary. Change to get equal sides of 9' 6" Fiberglass length is not critical, however the equal wire length of 9' 6" is very critical.

FIGURE 4 GAMMA MATCH MOUNTING

Mount the (2) gamma matches (**GO 1P**) to the horizontal and vertical driven elements, using the gamma straps (**Z02P**, **Z08P**) and attaching hardware as shown. Attach your 52 ohm coaxial cables to the connectors (**S42**) and dress along boom and down the mast.

ADJUSTING STANDING WAVE RATIO

Refer to Figure 4. The dimensions given are approximate and should be used as a starting point. The following instructions cover the adjustment of one gamma match. To adjust the second gamma match, simply repeat this procedure.

The gamma match has 2 adjustments. First is the capacitor adjust and the second is the slider adjust. Connect a S.W.R bridge to the coax between your transmitter and the antenna and check the S.W.R. If adjustment is required loosen the clamp on the gamma match and the screws holding the slider (Gamma Straps **Z02P**). Next move the capacitor adjustment first in one direction then the other until a minimum S.W.R. reading is obtained. If S.W.R. is not yet satisfactory, move the slider out 2" away from the boom. If the reading has gone up, move the slider back to the original position and then 2" toward the boom. Now readjust the capacitor for minimum S.W.R. you should now be able to determine which direction to move the slider. Repeat the above procedure moving the slider in smaller increments until a satisfactory S.W.R. reading is obtained. Tighten all hardware. Disconnect the S.W.R. bridge and reconnect your coaxial cable.

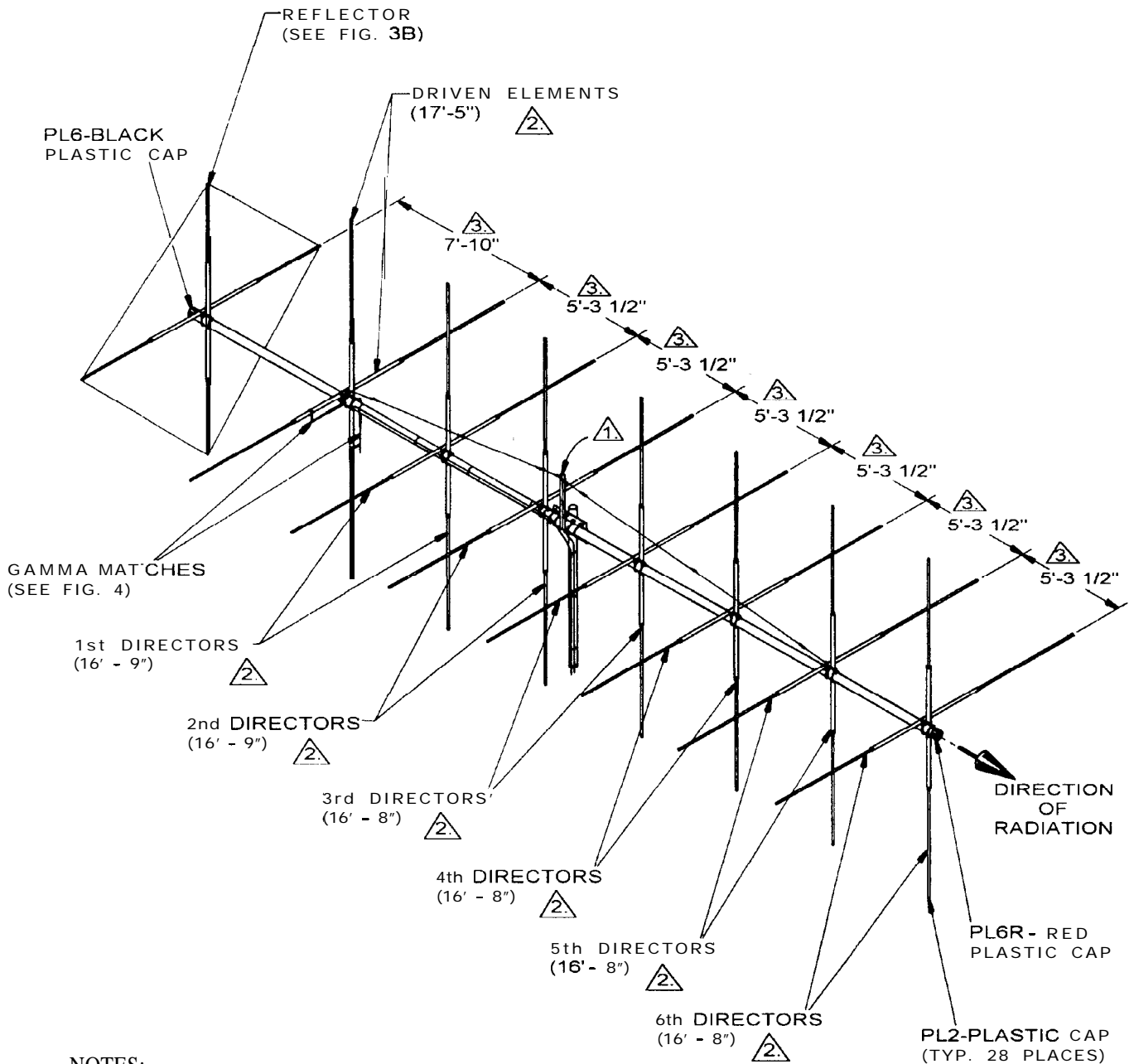

NOTES:

- *1. For details of boom assembly and mast mounting see figure 2.
- *2. For details of element assembly and mounting see figure 3.
- *3 Horizontal and vertical element spacing dimensions are identical with 1/4" gap between boom-to-element mounts. (see figure 3C)

FIGURE 1

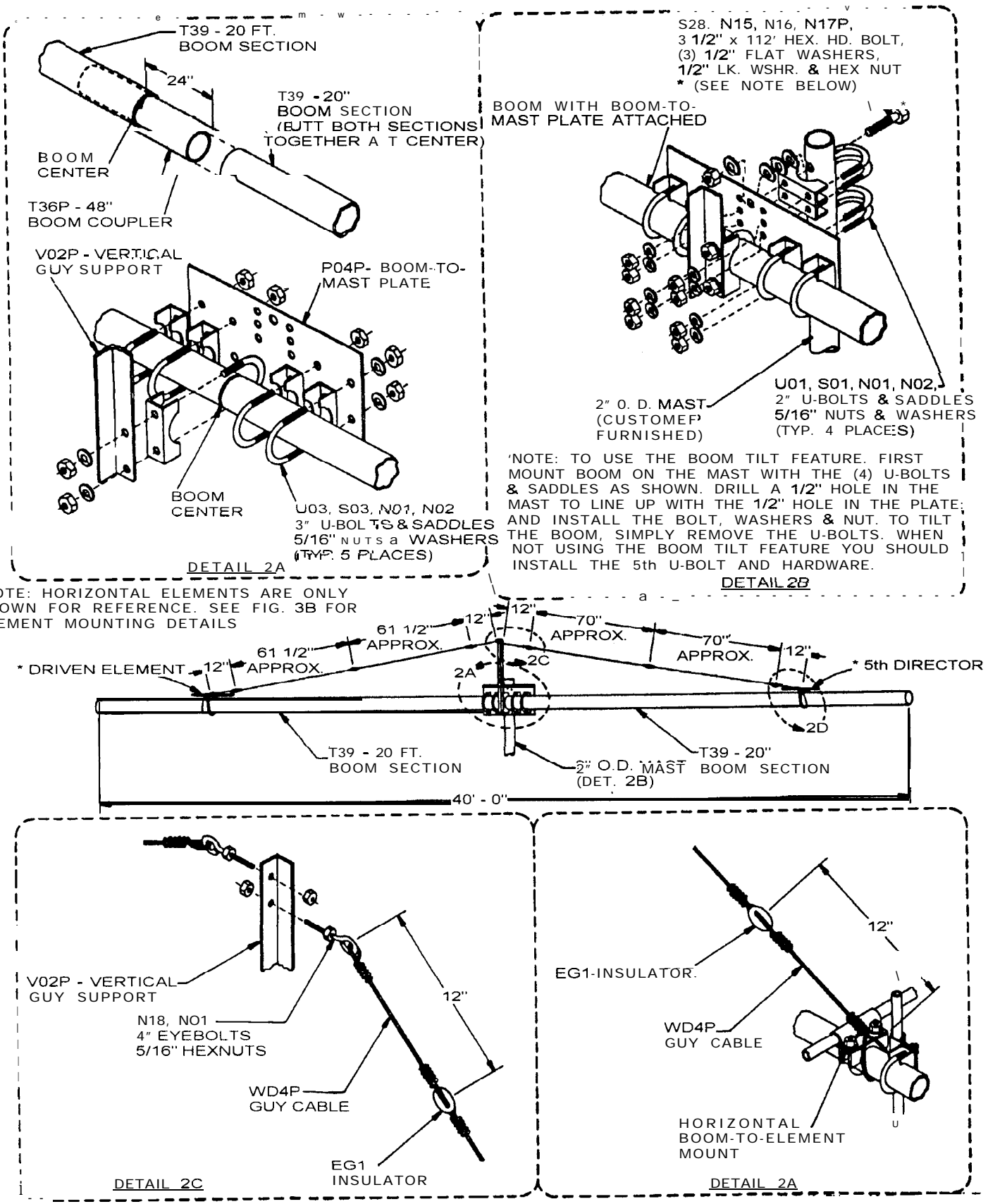
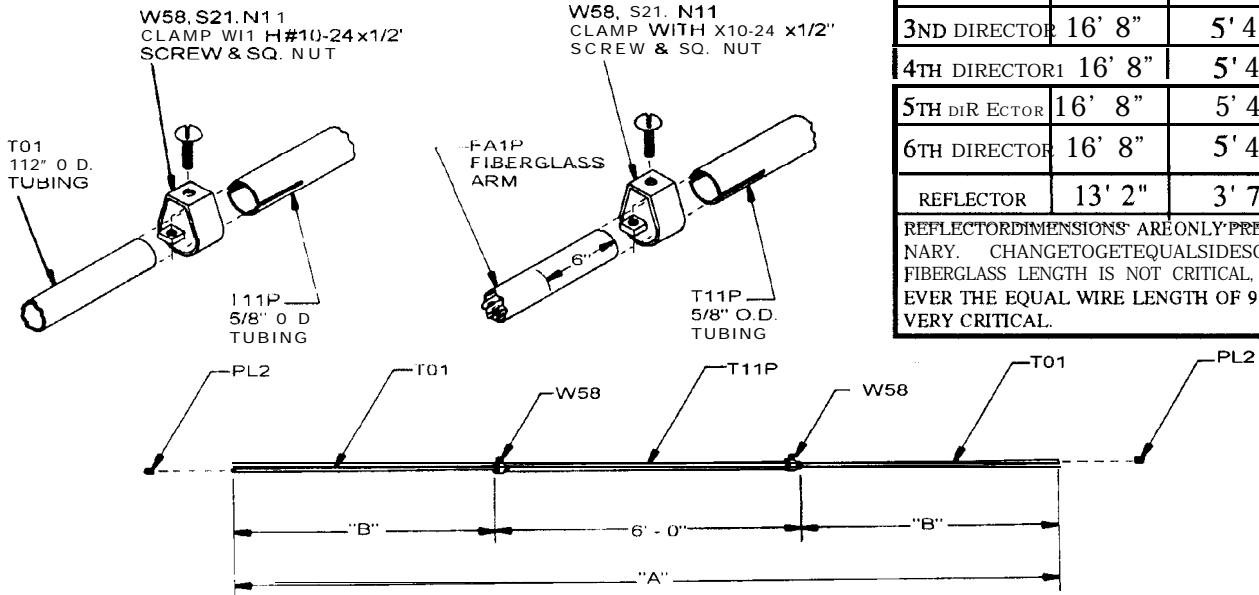

FIGURE 2

	DIMENSION	
	A	B
DRIV. ELEMENT	17' 5"	5' 8-1/2"
1ST DIRECTOR	16' 9"	5' 4-1/2"
2ND DIRECTOR	16' 9"	5' 4-1/2"
3RD DIRECTOR	16' 8"	5' 4"
4TH DIRECTOR	16' 8"	5' 4"
5TH DIRECTOR	16' 8"	5' 4"
6TH DIRECTOR	16' 8"	5' 4"
REFLECTOR	13' 2"	3' 7"

REFLECTOR DIMENSIONS ARE ONLY PRELIMINARY. CHANGE TO GET EQUAL SIDES OF 9'6". FIBERGLASS LENGTH IS NOT CRITICAL, HOWEVER THE EQUAL WIRE LENGTH OF 9' 6" IS VERY CRITICAL.



ELEMEN I ASSEMBLY (FIGURE 3A)

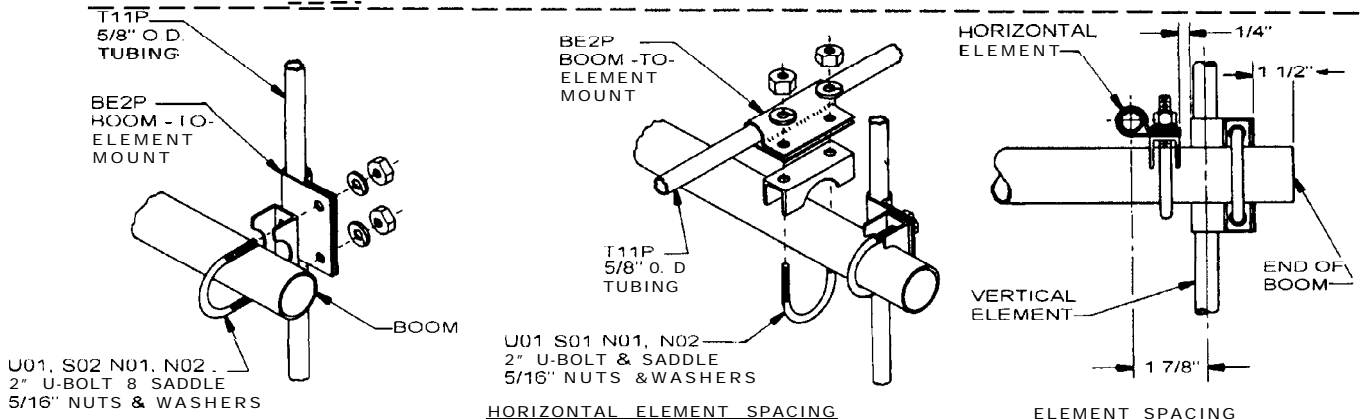

VERTICAL ELEMENT MOUNTING

HORIZONTAL ELEMENT SPACING

ELEMENT SPACING

FIGURE 3B

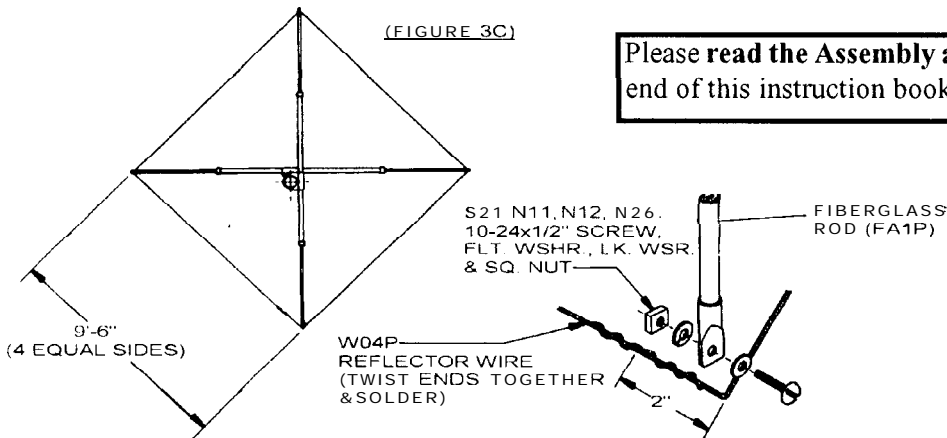

(FIGURE 3C)

Please read the Assembly and Troubleshooting Tips at the end of this instruction booklet before assembling elements.

FIGURE 3

* **NOTE.** THESE DIMENSIONS ARE APPROXIMATE. REFER TO THE INSTRUCTIONS ON ADJUSTING THE S.W.R. TO DETERMINE EXACT SETTINGS. THERE ARE 2 SEPARATE GAMMA ADJUSTMENTS, 1. CAPACITOR ADJUSTMENT, 2. SLIDER POSITION. **DO NOT MOVE BOTH AT THE SAME TIME.** MOVE THE CAPACITOR FIRST, THEN, IF NECESSARY MOVE THE SLIDER, AND GO BACK TO THE CAPACITOR.

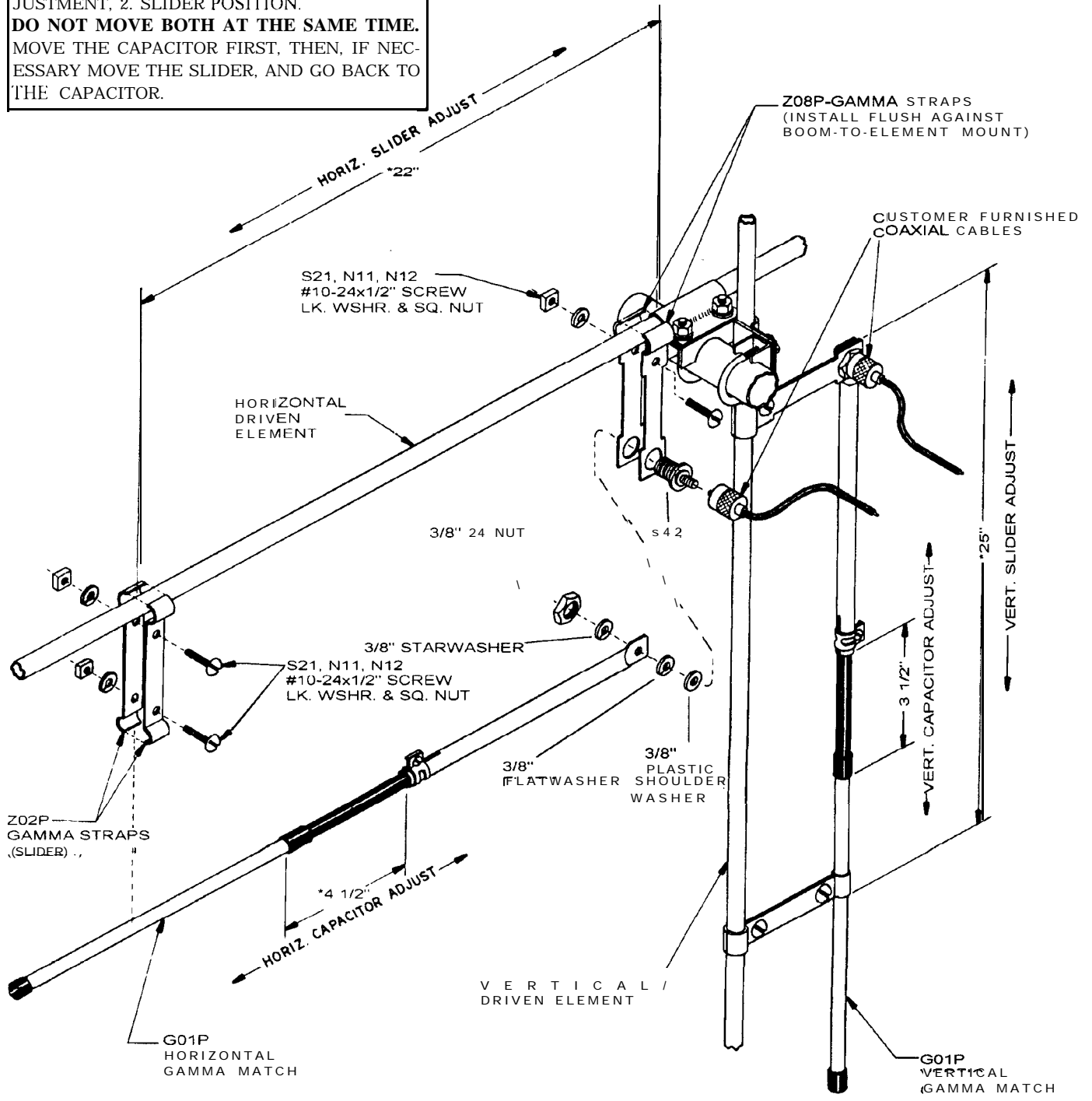

**LASER 500
GAMMA MATCH MOUNTING**

FIGURE 4



Caution:

**TAKE CARE TO AVOID ANY CONTACT WITH
OVERHEAD POWER LINES WHEN RAISING,
INSTALLING, OR REPAIRING YOUR
ANTENNA, TOWER, OR ROTOR.**

DEATH WILL OCCUR!



Installing and rigging towers, masts and antennas require specialized skills and experience. Information supplied by MACo assumes that all products will be installed by personnel having these skills and have installed similar products before. No one should attempt to install towers or masts without these knowledgeable skills.

MACo assumes no liability if faulty or dangerous installation practices are used. There are available, trained and experienced personnel to assist in installation, maintenance, or disassembly. Contact your local installer if consultation or assistance is required.

All tower and antenna installations should be thoroughly inspected at least twice a year by qualified, experienced, and trained personnel to insure proper performance and safety standards.

Electrical Warning

An additional warning precaution is given to be careful of surrounding high voltage power wires and other electrical hazards during installation of your tower, rotor, or antenna.

Do not erect a tower, rotor, or antenna during an electrical storm, rainstorm, or when lightning is a possibility.

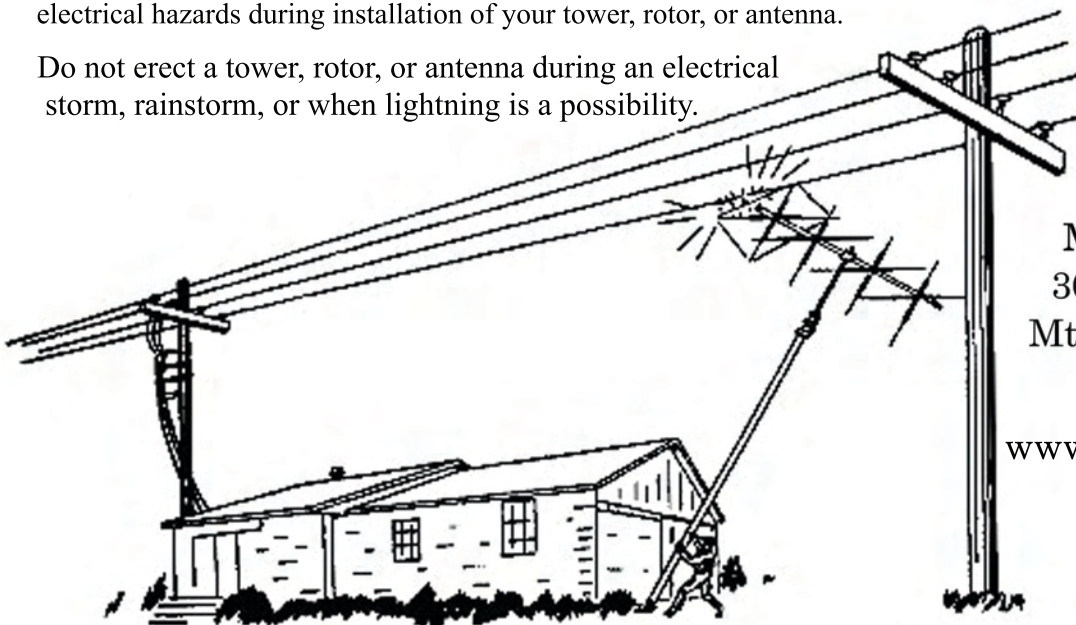

MACo Antennas
302 S. East Street
Mt. Carroll, IL 61053

www.macoantennas.net
(815) 244-3500

MACo Antennas is a Division of Charles Electronics, LLC